

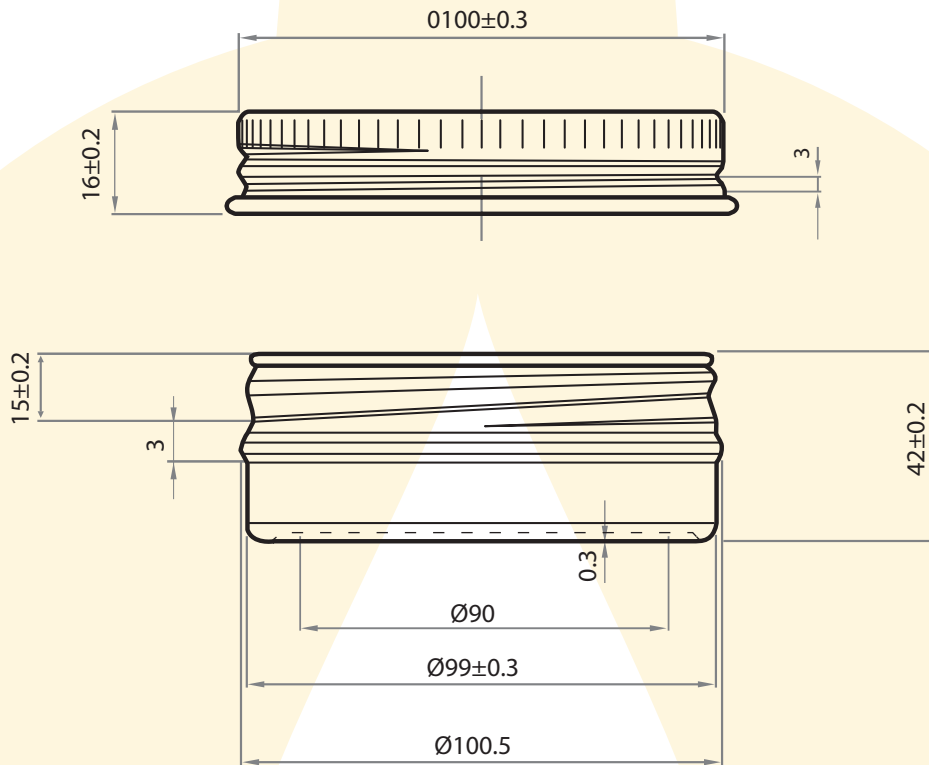

# NEW DIRECTIONS | AUSTRALIA

nda@newdirections.com.au | www.newdirections.com.au

47 CARRINGTON ROAD MARRICKVILLE, SYDNEY NSW 2204 AUSTRALIA | T: 612 8577 5999 | F: 612 8577 5977 | TOLL FREE: 1800 637 697



PRODUCT CODE	CMAC250
DESCRIPTION	250ml Aluminium Canister
WIDTH	100.5mm
HEIGHT	27.6mm $\pm 0.52$
NECK SIZE	N/A
MATERIAL	Aluminium
LINING	Cosmetic Grade Epoxy Resin Lining
LABEL DIMENSIONS*	LID & BASE LABELS: 96mm (D) WRAP AROUND: 310 (W) x 19mm (H)
BPA FREE	YES
RECYCLABLE	YES
NOTES	Aluminium Thickness: 0.4mm
DATE DRAWN	Feb/03/2016

Always store your packaging away from direct sunlight, at temperatures below 30°C  
 Product compatibility testing is highly recommended when selecting (new) packaging.  
 Always make sure you perform stability testing of your product in it's final packaging

*\*New Directions recommends testing the label size against physical sample of packaging prior to producing labels.*